



OH720, OP720, HI720, HI722

Cerberus® PRO

Automatic fire detectors



For the automatic addressable detector bus C-NET

- The optimum smoke detector for all applications
- Signal processing with detection algorithms
- Automatic address allocation during commissioning
- Reliable detection of emerging fires
- Suitable for air speeds up to 5 m/s for OH720 and OP720
- Communication via C-NET (individual addressing)

- **Environmental**

- ecologically processing
- recyclable materials
- electronic and synthetic material simply separable

- **Characteristics**

- resistant to environment and interference factors such as dust, fibers, insects, humidity, extreme temperatures, electro-magnetic interference, corrosive vapors, vibration
- insensitive to impact, tamper protection
- protected electronics, high-quality components
- integrated short-circuit isolator, which locate the defective part on the detector bus of the control unit and insulates between 2 detectors
- built-in alarm indicator (AI), visible at 360°
- up to 2 external alarm indicators of type FDAI91/FDAI92/FDAI93 connectable per detector
- signal processing with detection algorithms
- automatic address allocation during commissioning
- the same detector base type can be used for each detector type, for surface and recess supply wiring

- **Optional accessories**

- Detector locking device LP720 as protection against theft
- Designation plate FDBZ291
- Detector base seal RS720 for higher protection category
- Micro terminal DBZ1190-AA (0.28 ... 0.5 mm²)
- Connection terminal DBZ1190-AB (1.0 ... 2.5 mm²)
- Sounder base DBS720

OH720 Multi-sensor smoke detector



Multi-sensor smoke detector consist of:

- Detector
- Dust cap to cover the detector for protection against dust during construction work

Function

- works according to the scattered light principle with one sensor, optical forward scattering
- Opto-electronic sampling chamber holds off disturbing extraneous light but optically detects smoke particles
- an additional heat sensor increases the fire detector's immunity to deceptive phenomena
- selectable detection behavior by different parameter sets
- immunity against transient false alarm causes

Application

- for the detection of flaming fires caused by the combustion of liquid and solid matters, as well as smoldering fires
- for reliable fire detection in environments with deceptive phenomena

OP720 Smoke detector



Smoke detector consist of:

- Detector
- Dust cap to cover the detector for protection against dust during construction work

Function

- works according to the scattered light principle with one sensor, optical forward scattering
- Opto-electronic sampling chamber holds off disturbing extraneous light but optimally detects smoke particles
- selectable detection behavior by different parameter sets

Application

- for the detection of smoke-generating flaming and smoldering fires

HI720 Heat detector (static+RoR)



Heat detector consist of:

- Detector
- Dust cap to cover the detector for protection against dust during construction work

Function

- equipped with one heat sensor
- for high requirements
- certain response behavior with slow and fast temperature increases, also by depth temperature
- selectable detection behavior by different parameter sets

Application

- suitable in areas in which occur different environment temperatures
- where high dust or dirt developments or large humidity which can the impact of conventional alarm units to impair

HI722 Heat detector (static)



Heat detector consist of:

- Detector
- Dust cap to cover the detector for protection against dust during construction work

Function

- equipped with one heat sensor
- measures the ambient temperature, when the maximum temperature is exceeded the detector sends a danger signal to the fire control panel

Application

- suitable in areas, in which temporary high variations in temperature arise
- where high dirt and heat fluctuation which can the impact of conventional alarm units to impair

Detector bases DB721



Function

- Universal base for all point detectors of the series Cerberus PRO FD720

Application

- for recess supply wiring
- for surface supply wiring, cable diameter up to 8 mm

By using a detector base with loop contact (DB721) the detector line is not interrupted even if no point detector is mounted.

Detector base DB722



Function

- Universal base with detector base seal and screwless terminals for the OP720 and OH720 point detectors of the series Cerberus PRO FD720

Application

- for recess supply wiring
- for surface supply wiring, cable diameter up to 8 mm

Base attachment BA720



Application

- For the supply of surface-mounted tubes (max. 20 mm) and trunking (max. 25 mm x 15 mm)
- The detector is fixed with a spring-loaded catch.

● **Simple installation**

- Universal base with
 - 2 break outs on the side for surface supply wiring at max. Ø8 mm
 - extra large rear opening for easy recess supply wiring
- extra-large mounting slots facilitate a re-use of existing drill holes resulting from other systems
- connecting terminals for cable diameter at 1.6 mm²
- place for auxiliary terminals 2x DBZ1190-AA and 2x DBZ1190-AB
- detector can be easily turned into the base by hand, or with the detector exchanger DX791

Place for auxiliary terminals DBZ1190-AA, DBZ1190-AB

Connecting terminals detector line and ext. AI

Opening for cable entry AI

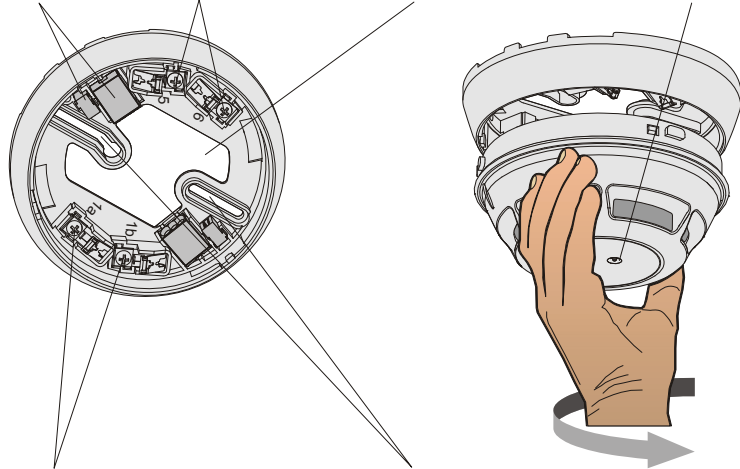

Connecting terminals detector line and ext. AI

Mounting slots min. 40 mm up to max. 90 mm

- alarm indicator (AI) centered in the detector; no alignment required

LP720 Detector locking device



- to protect the detector against theft

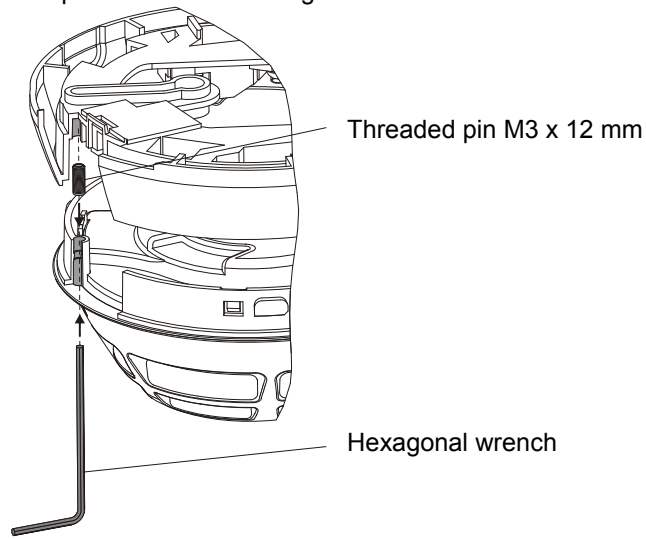

FDBZ291 Designation plate



- to identify the location address
- application without detector base seal RS720 only

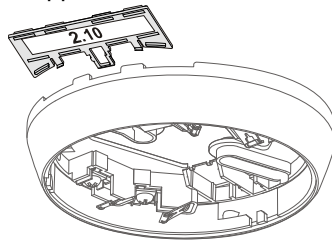

RS720 Detector base seal



- for higher protection category

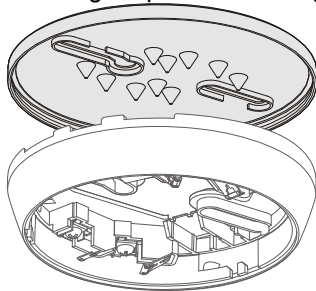

DBZ1190-AA Micro terminal, DBZ1190-AB Connection terminal



- for conductors of max. 0.5 mm²



- for conductors of max. 2.5 mm²
- support point for T-branching connection, extern alarm indicators (AI) or cable shielding
- place for max. 2 additional terminals each

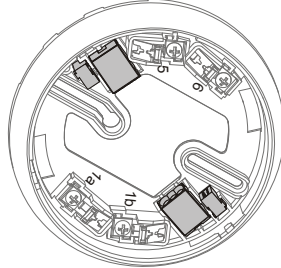

DBS720 Sounder base



- the addressable sounder base is used for acoustic alarming
- applicable with all point detectors of the series Cerberus PRO FD720

→ Description see data sheet A6V10203095

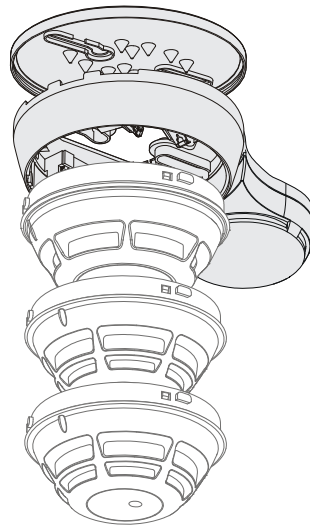

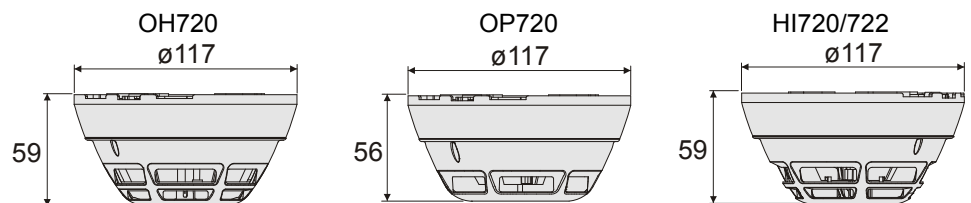

Dimensions of detector with base





Technical data

	OH720	OP720	HI720 / HI722
Operating voltage (modulated)	DC 12 ... 33 V	DC 12 ... 33 V	DC 12 ... 33 V
Operating current (quiescent)	~230 µA	~220 µA	~200 µA
Ext. alarm indicator without sounder base AI connectable and programmable	2	2	2
Operating temperature	-10 ... +55 °C	-10 ... +55 °C	-10 ... +55 °C
Storage temperature	-30 ... +70 °C	-30 ... +70 °C	-30 ... +70 °C
Humidity (short-term moisture condensation permitted)	≤95 % rel.	≤95 % rel.	≤95 % rel.
Communication protocol	C-NET	C-NET	C-NET
Color	white, ~RAL 9010	white, ~RAL 9010	white, ~RAL 9010
Protection category EN60529 / IEC529	IP40	IP40	IP40
– with detector base seal RS720	IP42	IP42	IP42
Standards	CEA4021, EN 54-7, EN 54-17	EN 54-7, EN 54-17	EN 54-5, EN 54-17
Approvals			
– VdS	G209064	G209068	G209065 /G209146
– LPCB	531d/01	531e/01	531f/01 / 531f/02
– FM	3038424	3038424	3037921
– Marine			
– MED (Marine Equipment directive)		19 485 – 11 HH	
– GL (Germanischer Lloyd)		19 563 – 11 HH	
Permissible air speed	max. 5 m/s	max. 5 m/s	–
System compatibility C-NET		FS720	
QS standards		Siemens Standard SN 36350	

OH720

Siemens Schweiz AG, CH-6301 Zug Date: see manufacturing date on the product 0786-CPD-20711
EN54-7, EN54-17 Point multi-sensor smoke detector; Safety in case of fire OH720 Technical data see Doc. A6V10212047

OP720

Siemens Schweiz AG, CH-6301 Zug Date: see manufacturing date on the product 0786-CPD-20713
EN54-7, EN54-17 Point smoke detector; Safety in case of fire OP720 Technical data see Doc. A6V10212047

HI720

Siemens Schweiz AG, CH-6301 Zug Date: see manufacturing date on the product 0786-CPD-20712
EN54-17 EN54-5, classes A2R, A2S Point heat detector; Safety in case of fire HI720 Technical data see Doc. A6V10212047

HI722

Siemens Schweiz AG, CH-6301 Zug Date: see manufacturing date on the product 0786-CPD-20793
EN54-17 EN54-5, classe A2S Point heat detector; Safety in case of fire HI722 Technical data see Doc. A6V10212047

Details for ordering

	Type	Part no	Designation	Weight
	OH720	S54310-F2-A1	Multi-sensor smoke detector	0.144 kg
	OP720	S54310-F1-A1	Smoke detector	0.138 kg
	HI720	S54310-F4-A1	Heat detector (static + RoR)	0.130 kg
	HI722	S54310-F3-A1	Heat detector (static)	0.130 kg
	DB721	S54319-F11-A1	Detector base with loop contact	0.100 kg
	DB722	S54319-F19-A1	Detector base	0.140 kg
	BA720	S54319-F20-A1	Base attachment	0.050 kg
Accessories	LP720	S54319-F9-A1	Detector locking device (2 hexagonal key, 100 hexagonal socket pins)	0.040 kg
	BA720	S54319-F20-A1	Base attachment	0.100 kg
	FDBZ291	A5Q00002621	Designation plate (10x)	0.034 kg
	RS720	S54319-F8-A1	Detector base seal (10x)	0.014 kg
	DBZ1190-AA	BPZ:4677080001	Micro terminal 0.28 ... 0.5 mm ²	0.001 kg
	DBZ1190-AB	BPZ:4942340001	Connection terminal 1.0 ... 2.5 mm ²	0.007 kg

Details see equipment overview A6V10225323

Siemens Switzerland Ltd
Infrastructure & Cities Sector
Building Technologies Division
International Headquarters
Fire Systems
Gubelstrasse 22
CH-6301 Zug
Tel. +41 41 724 24 24
www.siemens.com/buildingtechnologies

© 2011 Copyright by
Siemens Switzerland Ltd
Data and design subject to change without notice.
Supply subject to availability.

Document no. **A6V10202198_g_en_--**
Edition 10.2011

Manual FD720
Section 2